



11738-84

( 4762-77)

Hexagon socket head cap screws, accuracy class A.  
Construction and dimensions

( 12 8400

01.01.85

1.

3 36  
2662—80.

4762—77,

2.

^

© ©

, 1984  
, 1999

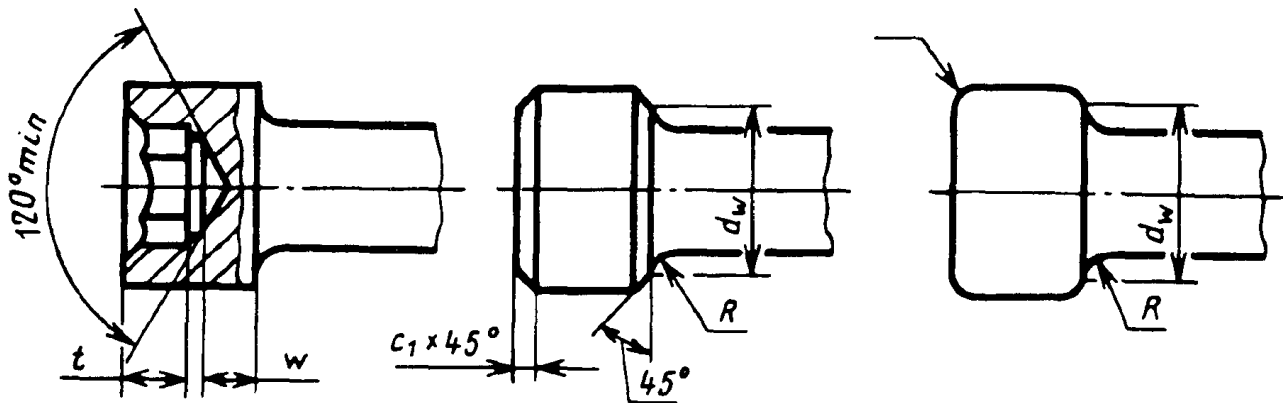
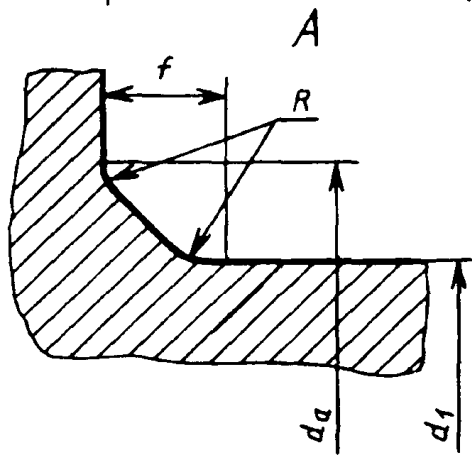
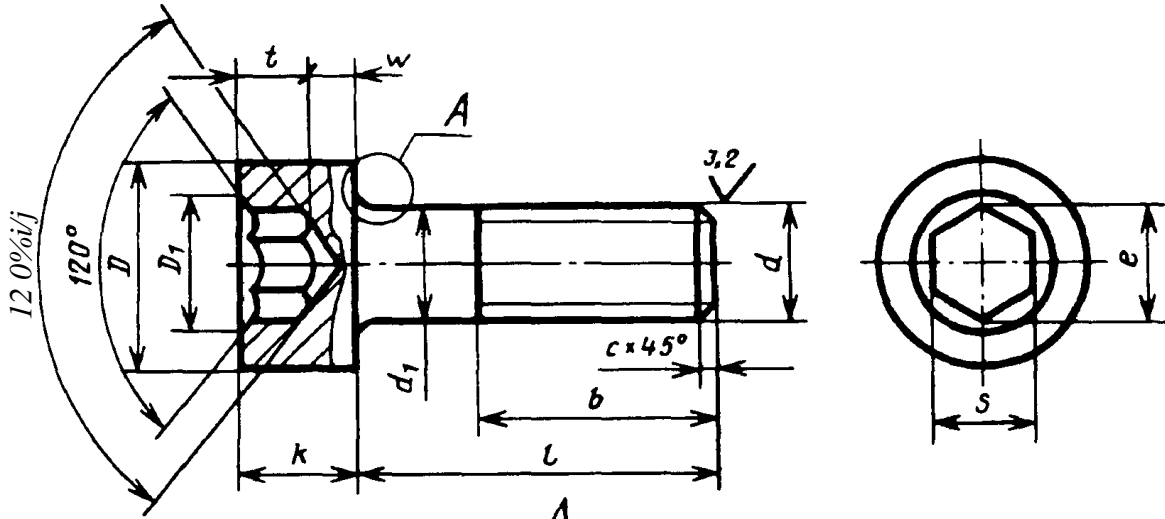

	3	4	5	6	8	10	12	(14)	16	(18)	20	(22)	24	(27)	30	(33)	36
d1	3	4	5	6	8	10	12	7	18	18	20	22	24	27	30	33	36
D	5,5	7,0	8,5	10,0	13,0	16,0	18,0	21,0	24,0	27,0	30,0	33,0	36,0	40,0	45,0	50,0	54,0
no <sub>s</sub> (17)		3,8	4,9	6,1	7,2	9,7	12,0	14,3	16,7	16,7	20,4	20,4	22,7	22,7	26,2	28,5	32,0
	3	4	5	6	8	10	12	14	16	18	20	22	24	27	30	33	36
S( < .	2,5	3,0	4,0	5,0	6,0	8,0	10,0	12,0	14,0	14,0	17,0	17,0	19,0	19,0	22,0	24,0	2
,	2,87	3,44	4,59	5,73	6,87	9,17	11,45	13,74	16,02	16,02	19,44	19,44	21,73	21,73	25,15	27,43	30,85
w,	1,15	1,4	1,9	2,3	3,0	4,0	4,8	5,8	6,8	7,8	8,6	9,4	10,4	11,9	12,9	13,8	15,3
/,	1,3	2,0	2,5	3,0	4,0	5,0	6,0	7,0	8,0	9,0	10,0	11,0	12,0	13,5	15,5	17,5	19,0
/	0,51	0,60	0,60	0,68	1,02	1,02	1,87	1,87	1,87	1,87	2,04	2,04	2,04	2,89	2,89	2,89	2,89
,	0,1	0,2	0,2	0,25	0,4	0,4	0,6	0,6	0,6	0,6	0,8	0,8	0,8	1,0	1,0	1,0	1,0
4	3,6	4,7	5,7	6,8	9,2	11,2	14,2	16,2	18,2	20,2	22,4	24,4	26,4	30,4	33,4	36,4	39,4
4,	5,07	6,53	8,03	9,38	12,33	15,33	17,23	20,17	23,17	26,02	28,87	31,85	34,81	38,72	43,61	48,62	52,54
	0,5	0,5	1,0	1,0	1,6	1,6	1,6	2,0	2,0	2,5	2,5	2,5	2,5	2,5	2,5	2,5	3,0
] ft,	0,3	0,4	0,5	0,6	0,8	1,0	1,2	1,4	1,6	1,8	2,0	2,2	2,4	2,7	3,0	3,3	3,6
^	18	20	22	24	28	32	36	40	44	48	52	56	60	66	72	78	84

> </	3	4	5	6	8	10	12	(14)	16	(18)	20	(22)	24	(27)	30	(33)	36
5																	
6																	
JL																	
12																	
14																	
16																	
'25'																	
30												-	-	.	.	-	-
35	-												-	-	-	-	-
40	-														.	-	-
45	-	-														.	.
50	-	-															
55	-	-	-														
60	-	-	.														
65	-	-	.	-													
70	-	-	-	-													
"75"		-	-	-													
80	-	-	-	-		-											
90	-	-	-	-													
100	-	-	-	-	-												
110	-	-	-	-	-	-											
120	-	-	-	-	-	-											
130	-	.	.	.	-	-											
140	-	-	-	-	-	-	-										
150																	
160																	
170	-	-	-	-	-	-		-	-	-							
180																	
JL																	
200		-	-	-													

/

d — 12 ,

6 g, / = 40 , 6,8, :

M12-6g 40.68 11738-84

10.9 ,

:

M12-6g 40.109.30 .05 11738-84

3. — 24705, — 27148.

2, 3. ( , . 1).

4. 1759.1.

5. ±

6. — 1759.2.

7. , — 19256.  $d_b$

8. —  $d^A$

9. — . 8,8 12,9,

10.

5.6; 6.8 10.9.

11. : ,

12. — 1759.0.

11, 12. ( , . 1).

13.

/,	1000 . , , </,																
	3	4	5	6	8	10	12	(14)	16	(18)	20	(22)	24	(27)	30	(33)	36
5,	0,72																
6	0,76	1,54															
8	0,85	1,70	2,90	-	-	-	-	-	-	-	-	-	-	-	-	-	-
10	0,94	1,85	3,15	4,90	-	-	-	-	-	-	-	-	-	-	-	-	-
12	1,03	2,01	3,39	5,25	10,99	-	-	-	-	-	-	-	-	-	-	-	-
	1,11	2,16		5,60	11,63	20,40	-	-	-	-	-	-	-	-	-	-	-
16	1,20	2,31	3,89	5,96	12,26	21,40	-	-	-	-	-	-	-	-	-	-	-
20	1,38	2,63	4,38	6,66	13,54	23,51	34,16	-	-	-	-	-	-	-	-	-	-
25	1,68	3,01	5,00	7,54	15,13	25,92	37,80	55,57	78,90	-	-	-	-	-	-	-	-
30	1,96	3,61	5,86	8,42	16,72	28,43	41,43	60,54	85,56	117,07	152,62	-	-	-	-	-	-
35	-	4,10	6,63	9,81	18,31	194	45,07	65,51	92,22	125,33	163,03	213,60	265,87	-	-	-	-
40	-	4,60	7,40	10,92	20,82	33,45	48,71	70,48	98,88	133,60	173,43	226,40	280,85	384,92	-	-	-
45	-	-	8,17	12,03	22,79	37,44	52,34	75,45	105,54	141,86	183,84	239,19	295,83	404,26	535,24	-	-
50	-	-	8,94	13,13	24,76	40,52	58,22	80,42	112,20	150,12	194,24	251,98	310,82	423,59	558,92	729,15	-
55	-	-	-	14,24	26,73	43,60	62,66	85,39	118,86	158,38	204,64	264,77	325,80	442,93	582,61	758,24	928,82
60	-	-	-	15,35	28,70	46,69	67,10	94,64	129,45	166,65	215,05	277,57	340,78	461,11	606,29	787,33	963,20
65	-	-	-	-	1,68	49,77	71,53	100,67	137,34	180,76	230,45	290,36	355,76	481,60	629,98	816,42	997,57
70	-	-	-	-	32,65	52,85	75,97	106,71	145,22	190,74	242,77	303,15	370,74	500,94	653,67	845,51	1031,95
75	-	-	-	-	34,62	55,93	80,41	112,75	153,11	200,72	255,09	324,00	385,72	520,27	677,36	874,60	1066,80
80	-	-	-	-	36,59	59,01	84,84	118,79	161,00	210,71	267,42	338,91	400,70	539,61	701,04	903,69	1100,71
90	-	-	-	-	-	65,17	93,72	11,87	176,77	230,67	292,07	368,74	447,26	578,28	748,42	961,87	1169,46
100	-	-	-	-	-	71,33	102,59	142,95	192,55	250,64	316,72	398,56	482,76	638,21	818,43	1020,05	1238,21
	-	-	-	-	-	-	111,46	155,03	208,32	270,60	341,37	428,39	518,25	683,13	873,89	1078,24	1306,96
120	-	-	-	-	-	-	120,34	167,10	224,10	290,57	366,01	458,21	553,75	728,05	929,35	1173,91	1383,77
130	-	-	-	-	-	-	129,21	179,18	239,88	310,54	390,66	488,04	589,24	772,98	984,81	1241,01	1495,58
140	-	-	-	-	-	-	-	191,26	255,65	330,50	415,31	517,86	624,74	817,90	1040,27	1308,12	1575,44
150	-	-	-	-	-	-	-	-	271,43	350,47	439,96	547,69	660,23	862,82	1095,73	1375,23	1655,30
160	-	-	-	-	-	-	-	-	287,20	370,43	464,61	577,51	695,73	907,75	1151,19	1442,34	1735,16
170	-	-	-	-	-	-	-	-	-	-	489,25	607,34	731,22	952,67	1206,65	1509,44	1815,03
180	-	-	-	-	-	-	-	-	-	-	513,90	637,17	766,71	997,59	1262,11	1576,55	1894,89
190	-	-	-	-	-	-	-	-	-	-	538,55	666,99	802,21	1042,52	1317,57	1643,66	1977,75
200	-	-	-	-	-	-	-	-	-	-	563,20	696,82	837,70	1087,44	1373,03	1710,77	2054,61

1. -

. . . , . . . , . . . , . . .

2. 07.02.84 432

3. 2662—80

4. 4762—77

5. 11738-72

6. -

--	--

1759.0-87	12
1759.1-82	4
1759.2-82	6
12414-94	
19256-73	7
24705-81	3
27148-86	3
2662-80	
4762-77	

7. 4—93 -  
( 4—94)

8 ]1£ £ ( 1999 .) 1, 1989 .( 5—89)

. . .  
. . .  
. . .

. . . 021007 10.08.95. 28.01.99. 24.02.99. . . .0,93. - . 0,85.  
190 . 2069. . 155.  
, 107076, , ., 14  
— .“ ”, , ., 6  
080102